

PRODUCT SPECIFICATIONS



PCB COMMERCIAL SERIES 50 Hz

SELF-CONTAINED PACKAGE AIR CONDITIONER

7½, 10, AND 15 TON
[26.4 kW to 52.8 kW]

COOLING CAPACITY:
90,000 TO 180,000 BTU/H



The PCB Commercial 50 Hz self-contained packaged air conditioner is designed for ground-level or rooftop application.

Standard Features

- Dual high-efficiency scroll compressors with internal motor protection (2-stage cooling; three compressors on 15-ton units)
- Compressor grommets for vibration isolation
- Time delay for compressor sequencing
- Fully charged systems
- High- and low-pressure controls on all systems
- Mild ambient switch
- Two independent condenser coils for 2-stage operation
- Totally enclosed, permanently lubricated ball-bearing outdoor fan motors
- Enhanced copper tube/aluminum fin coils
- Expansion valve evaporator coil
- Vertical discharge with removable grilles
- Galvanized steel, powder-coated drain pan with 3/4" (19mm) NPT condensate connection
- Belt-driven, variable-pitch sheave permits multi-speed adjustment
- Centrifugal fan for quiet and efficient operation
- Filters (2" [50.8mm] disposable) provided with unit
- Operates up to 125° F ambient temperature

Cabinet Features

- Heavy-gauge, zinc-coated steel cabinet with weather-resistant powder-paint finish
- Fully insulated with blankets of insulation
- Built-in filter rack
- Factory wiring conveniently arranged for installation of accessories
- Control box and compressors easily accessible from side access panels

Accessory Heat Kit Features

- Control circuitry arranged to readily permit staging
- Rust-resistant nickel chromium heating elements
- Primary and secondary limit protection
- Factory-installed one-time fuses on all models

Accessories

- Room thermostat; Low-ambient control
- Rooftop Lift Kit; Roof curb
- Economizers (horizontal and vertical)
- Manual/motorized fresh air damper
- Horizontal Duct Kit (Downflow to Horizontal Conversion)
- Electric heat capacities 15 kW-30 kW @ 415V 50 Hz (field-installed accessory)
- Panel Louver Kit

PRODUCT SPECIFICATIONS

SPECIFICATIONS

	PCB090-5	PCB120-5	PCB180-5
Total Cooling - BTU/h (kW)	88,400 (25.9)	118,600 (34.8)	172,000 (50.4)
Sensible Cooling - BTU/h ¹ (kW)	67,100 (19.7)	89,200 (26.1)	131,000 (38.4)
EER ²	8.9	9.7	8.5
Indoor Blower (Qty.)	2	2	2
Type	Belt	Belt	Belt
Size - D x W (mm)	12 x 12 (305 x 305)	12 x 15 (305 x 381)	12 x 15 (305 x 381)
Motor Horsepower (kW)	2 (1.49)	3 (2.24)	5 (3.73)
Indoor CFM Nominal (L/S)	3000 (1416)	4000 (1888)	5600 (2643)
Evaporator Coil (Qty.)	1	1	1
Face Area - Ft. ² (m ²)	9.3 (0.86)	14.0 (1.3)	14.0 (1.3)
Rows/FPI (FPM)	3/16 (630)	3/16 (630)	3/16 (630)
Tube Diameter (mm)/Material	3/8" (9.5)/Copper	3/8" (9.5)/Copper	3/8" (9.5)/Copper
Filter Size/Qty. (mm)	25" x 25" x 2" (635 x 635 x 8.51)/3	16" x 25" x 2" (406 x 635 x 51)/3 20" x 25" x 2" (508 x 635 x 51)/3	16" x 25" x 2" (406 x 635 x 51)/3 20" x 25" x 2" (508 x 635 x 51)/3
Outdoor Fan (Qty.)	2	2	4
Fan Diameter (mm)	24" (610)	24" (610)	22" (559)
Motor Horsepower (kW)	1/2 (0.37)	1/2 (0.37)	1/2 (0.37)
Outdoor CFM Nominal (L/S)	4300 (2030)	6100 (2880)	7000 (3300)
Condenser Coil (Qty.)	1	1	1
Face Area Total - Ft. ² (m ²)	15.6 (1.45)	23.8 (2.21)	23.8 (2.21)
Rows/FPI (FPM)	2/21 (827)	2/21 (827)	3/16 (630)
Tube Diameter (mm)/Material	3/8 (9.5)/Copper	3/8 (9.5)/Copper	3/8 (9.5)/Copper
Number of Compressors	2	2	3
Volts-Phase	380-415-3	380-415-3	380-415-3
Compressor RLA/LRA	6.7/47.5	9.5/73.0	9.5/73.0
Blower FLA - Indoor/Outdoor	3.4/1.7	4.2/1.7	7.3/1.7
Minimum Circuit Ampacity ³	23.6	31.3	49.5
Maximum Fuse Size	30	50	60
Ship Weight - lbs. (kg)	990 (449.5)	1215 (551.6)	1460 (662.8)

¹ Sensible capacity is gross, with no deduction for indoor motor heat

² BTU/Watt @ 80/67°F (26.7/19.4°C) inside - 95°F (35°C) outside air

³ Wire size should be in accordance with Local Electrical Codes. Extensive wire runs will require larger wire sizes.

NOMENCLATURE

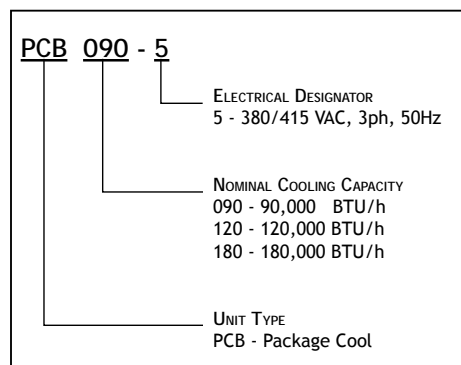

DIMENSIONS

All dimensions in inches and millimeters. Drawings are not to scale.

FIGURE 1. VERTICAL DISCHARGE

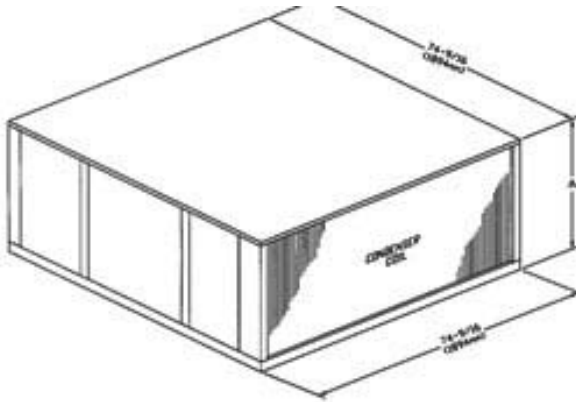

See curb details for connection of duct work to curb. Duct work is not intended to be connected to unit.

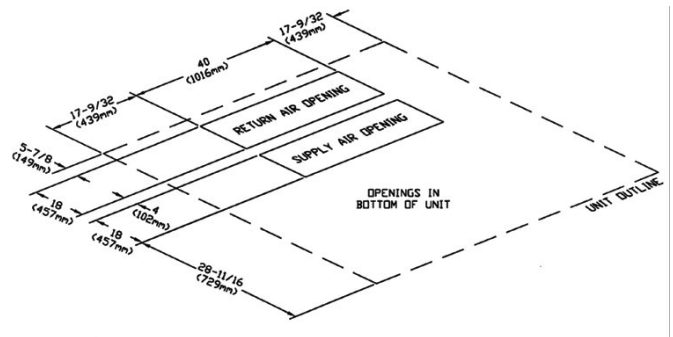
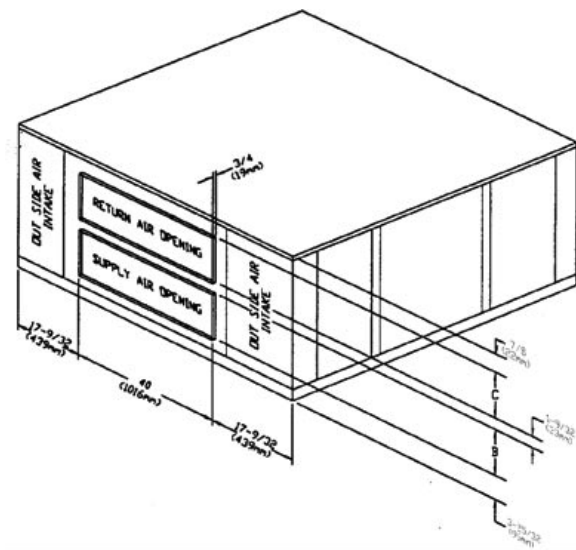

FIGURE 2. HORIZONTAL DISCHARGE



Note: The Horizontal Conversion Kit is required to convert a factory duct configuration (downflow) to a horizontal duct configuration, as shown in Figure 2.

UNIT SIZE	A - HEIGHT	B - SUPPLY AIR	C - RETURN AIR
090	36" (914 mm)	12½" (318 mm)	179/16" (446 mm)
120,180	52" (1321 mm)	20¼" (514 mm)	2513/16" (656 mm)

PRODUCT SPECIFICATIONS

ELECTRICAL CONNECTIONS

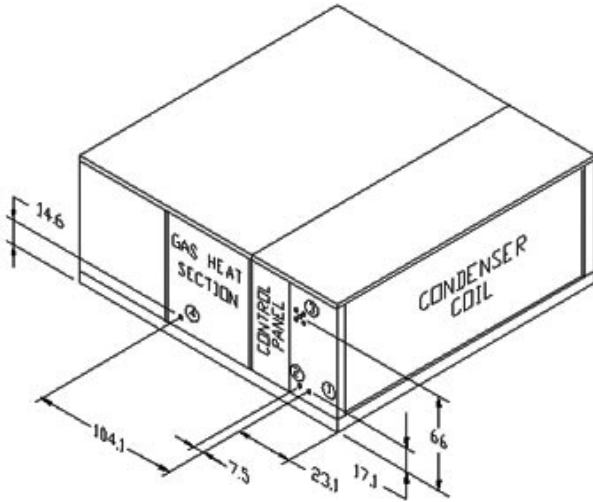

MODEL	B
PCB090-5	7 $\frac{7}{8}$ " (200 mm)
PCB120-5	23 $\frac{3}{8}$ " (606 mm)
PCB180-5	23 $\frac{3}{8}$ " (606 mm)

- 1- Main power entrance location (with electric heat installed)
- 2- Control wiring entrance location
- 3- Main power entrance location (without electric heat installed)

Note: Single-point wiring is available at location #1 when heat kit is installed. See installation instructions for heat kits.

FIGURE 3. ELECTRICAL HEAT UNITS

ELECTRIC HEAT

ELECTRIC HEAT AIR TEMPERATURE RISE @ NOMINAL VOLTAGE

Heater Model	HKCB20	HKCB30	HKCB40
No. Stages	2	2	2
Output MBH (W)	67.5 (19.8)	101.3 (29.7)	135.0 (39.6)
CFM & (L/S)	2600 (1227)	24.2 (13.4)	36.2 (20.1)
	2800 (1320)	22.5 (12.5)	33.6 (18.7)
	3000 (1415)	21.0 (11.7)	31.4 (17.4)
	3200 (1510)	19.7 (10.9)	29.4 (16.3)
	3400 (1605)	18.5 (10.3)	27.7 (15.4)
	3600 (1700)	17.5 (9.7)	26.2 (14.6)
	3800 (1793)	16.5 (9.2)	24.8 (13.8)
	4000 (1888)	15.7 (8.7)	23.5 (13.1)
	4200 (1982)	15.0 (8.3)	22.4 (12.4)
	4400 (2076)	14.3 (7.9)	21.4 (11.9)
	4600 (2171)	13.7 (7.6)	20.5 (11.4)
	4800 (2265)	13.1 (7.3)	19.6 (10.9)
	5000 (2360)	12.6 (7.0)	18.8 (10.4)
	5200 (2454)	12.1 (6.7)	18.1 (10.1)
	5400 (2548)	11.6 (6.4)	17.4 (9.7)
	5600 (2643)	11.2 (6.2)	16.8 (9.3)
5800 (2737)	10.8 (6.0)	16.2 (9.0)	
6000 (2832)	10.5 (5.8)	15.7 (8.7)	

Notes:

1. Maximum air temperature rise of 40° F (22.2° C) must not be exceeded.
2. See Electric Heater Availability table for various unit sizes.
3. Air temperature rise is for total heating capacity: Temperature rises at other conditions may be calculated by using the formula:

$$\text{Temperature Rise} = \frac{\text{Output Capacity} - \text{BTU/h}}{1.08 \times \text{ft}^3/\text{min. Airflow}}$$

Note: Temperature rises must be calculated in other than nominal voltage conditions.

4. For altitudes over 2,000', air temperature rise must be calculated using the formula:

$$\text{Temperature Rise} = \frac{\text{Output Capacity} - \text{BTU/h}}{14.4 \times \text{ft}^3/\text{Min. Airflow} \times \text{Specific Weight of Air}}$$

5. Operation at less than nominal voltages must be de-rated by the following factors: 415 volt-0.75; 380 volt-0.63.

NOMINAL VOLTAGE FOR HKCB

	@ 480V	@ 415V	@ 380V
HKCB20-4	19.8 kW	14.9 kW	12.5 kW
HKCB30-4	29.7 kW	22.3 kW	18.7 kW
HKCB40-4	39.6 kW	29.7 kW	25.0 kW

ELECTRIC HEATER AVAILABILITY

Unit Size	HKCB20	HKCB30	HKCB40
7 $\frac{1}{2}$	X	X	X
10	X	X	X
15	X	X	X

FAN PERFORMANCE DATA

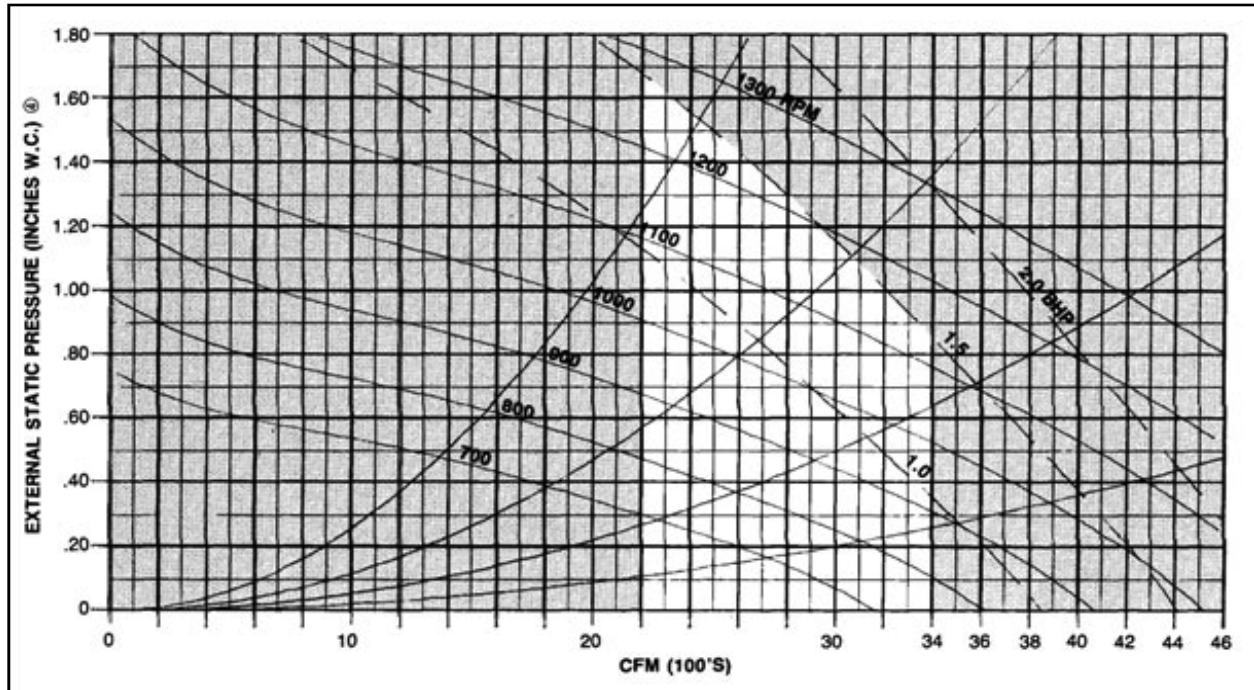

FIGURE 4. FAN CURVE - PCB 090

SUPPLY FAN PERFORMANCE - PCB090

CFM	EXTERNAL STATIC PRESSURE (INCHES W.C.) SEE NOTE (3)															
	0.2		0.4		0.6		0.8		1.0		1.2		1.4		1.6	
	RPM	BHP	RPM	BHP	RPM	BHP	RPM	BHP	RPM	BHP	RPM	BHP	RPM	BHP	RPM	BHP
2600	<i>669</i>	<i>0.44</i>	816	0.59	916	0.75	1004	0.92	1084	1.09	1157	1.28	1226	1.47	1291	1.67
2800	<i>734</i>	<i>0.53</i>	847	0.69	944	0.85	1030	1.03	1109	1.21	1181	1.40	1249	1.60	1312	1.91
3000	<i>770</i>	<i>0.62</i>	877	0.79	973	0.97	1053	1.15	1135	1.34	1206	1.54	1273	1.75	1336	1.96
3200	<i>807</i>	<i>0.73</i>	909	0.91	1002	1.10	1086	1.29	1162	1.49	1232	1.70	1298	1.91	1360	2.12
3400	<i>845</i>	<i>0.85</i>	942	1.04	1032	1.24	1114	1.44	1159	1.65	1259	1.87	1324	2.09	1384	2.31

Notes:

- Selections in *ITALICS* require a field drive change. See following table below for drive ranges.
- Table includes all internal pressure drops including cabinet losses. See Pressure Drops table that must be considered as part of external static pressure drop.
- DO NOT SELECT IN SHADED AREAS (FOR INTERPOLATION ONLY).

SUPPLY FAN DRIVE DATA - PCB090

MOTOR SHEAVE - ADJUSTABLE		FACTORY SETTING					
FAN SHEAVE - FIXED		2 TURNS OPENS					
MOTOR SHEAVE TURNS OPEN		0	1	2	3	4	5
FAN RPM	2.0 HP MOTOR	1209	1146	1082	1018	955	891

Note: Allow ±5% variation in blower RPM due to pulley manufacturing tolerances.

Conversion Factor:
 1 CFM = 0.472 L/S
 1" W.C. = 2.5 M Bar
 1 HP = 0.747 kW

PRODUCT SPECIFICATIONS

FAN PERFORMANCE DATA (CONT.)

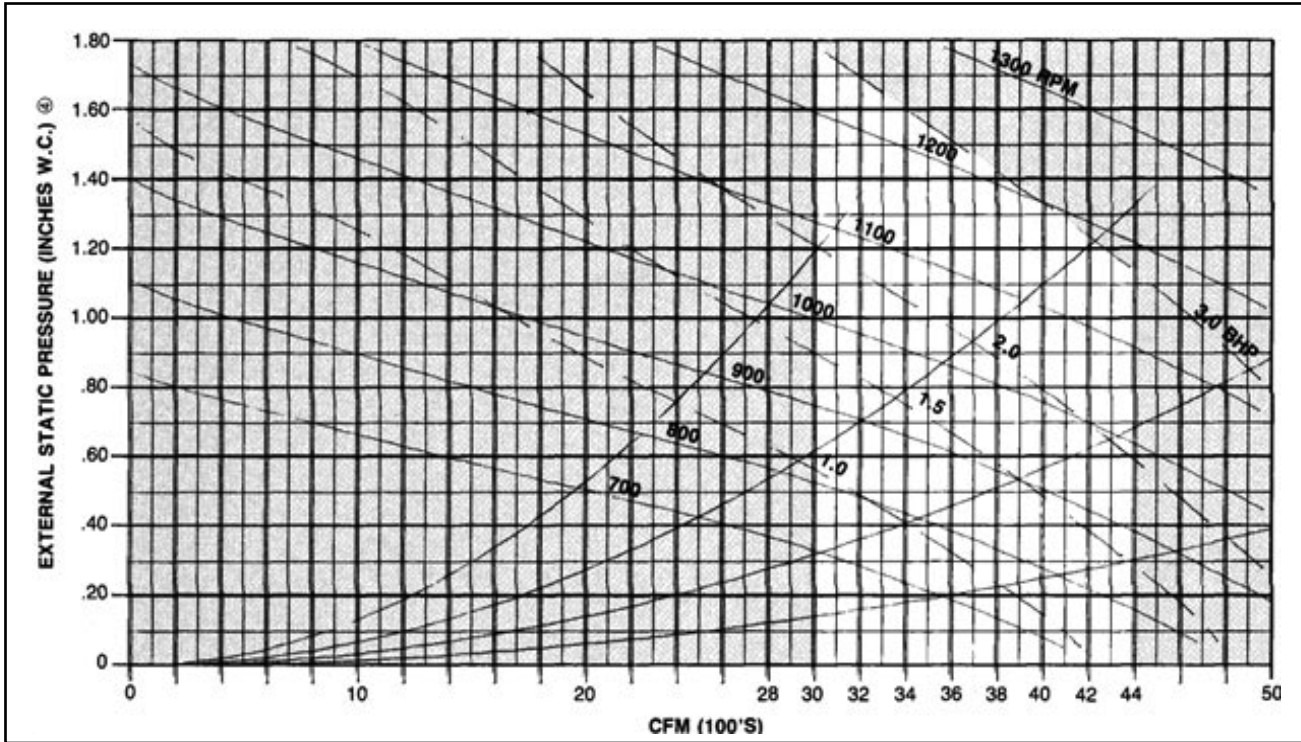

FIGURE 5. FAN CURVE - PCB 120

SUPPLY FAN PERFORMANCE - PCB120

CFM	External Static Pressure (INCHES W.C.)															
	0.2		0.4		0.6		0.8		1.0		1.2		1.4		1.6	
	RPM	BHP	RPM	BHP	RPM	BHP	RPM	BHP	RPM	BHP	RPM	BHP	RPM	BHP	RPM	BHP
3400	<i>679</i>	<i>0.73</i>	<i>781</i>	<i>0.98</i>	873	1.26	957	1.58	1034	1.91	1105	2.26	1171	2.26	1233	2.99
3600	<i>706</i>	<i>0.83</i>	805	1.10	894	1.39	975	1.71	1051	2.05	1121	2.41	1188	2.78	<i>1249</i>	<i>3.17</i>
3800	<i>733</i>	<i>0.95</i>	829	1.23	916	1.53	995	1.85	1069	2.20	1139	2.57	1204	2.95	1266	3.36
4000	<i>761</i>	<i>1.07</i>	855	1.37	938	1.68	1016	2.01	1088	2.36	1156	2.74	1221	3.14	1282	3.55
4200	790	1.21	880	1.52	961	1.84	1037	2.18	1108	2.54	1175	2.93	1239	3.33	1299	3.75
4400	818	1.36	906	1.68	985	2.01	1059	2.36	1128	2.73	1194	3.13	1257	3.54	1316	3.97

Notes:

- Selections in *ITALICS* require a field drive change. See following table below for drive ranges.
- Table includes all internal pressure drops including cabinet losses. See Pressure Drops table that must be considered as part of external static pressure drop.

SUPPLY FAN DRIVE DATA - PCB120

		Motor Sheave - Adjustable		Factory Setting			
		Fan Sheave - Fixed		Two Turns Opens			
Motor Sheave Turns Open		0	1	2	3	4	5
Fan RPM	3.0 HP Motor	1242	1186	1129	1073	1016	960

Note: Allow ±5% variation in blower RPM due to pulley manufacturing tolerances.

Conversion Factor:

- 1 CFM = 0.472 L/S
- 1" W.C. = 2.5 M Bar
- 1 HP = 0.747 kW

FAN PERFORMANCE DATA (CONT.)

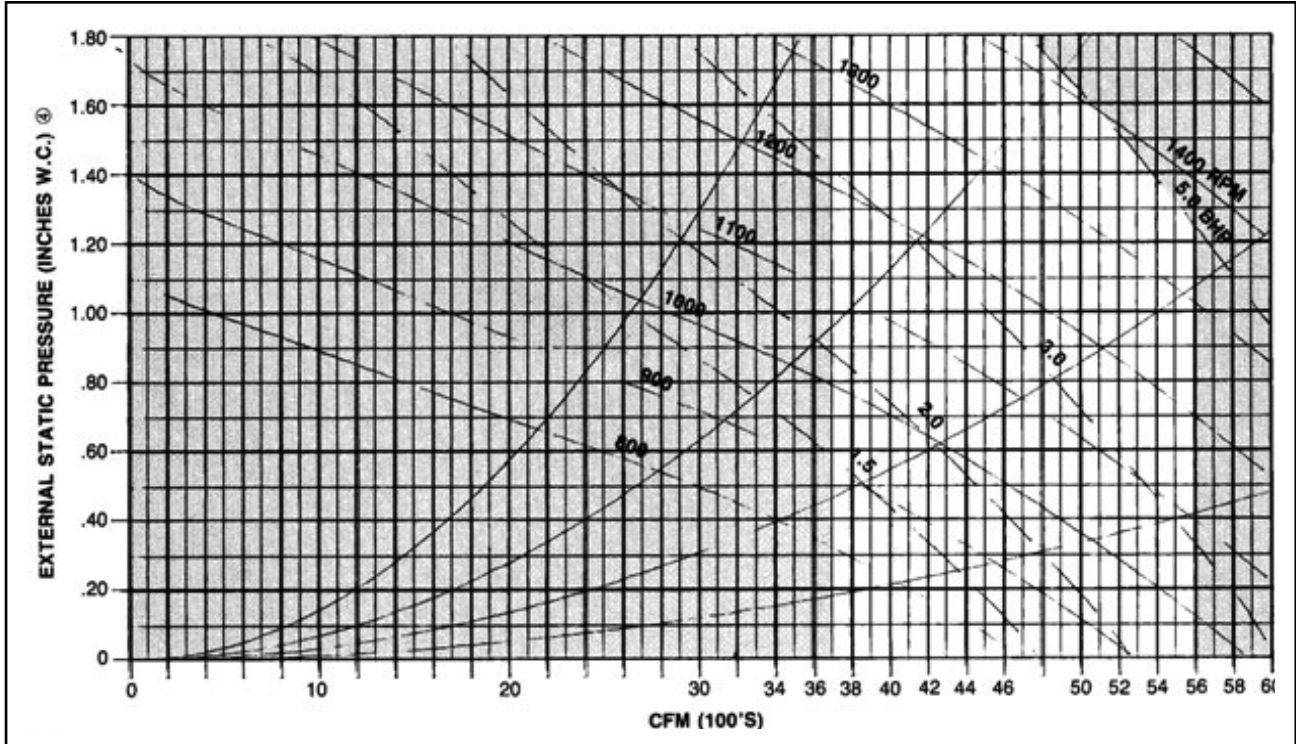

FIGURE 6. FAN CURVE - PCB180

SUPPLY FAN PERFORMANCE - PCB180

CFM	External Static Pressure (Inches W.C.) See Last Note															
	0.2		0.4		0.6		0.8		1.0		1.2		1.4		1.6	
	RPM	BHP	RPM	BHP	RPM	BHP	RPM	BHP	RPM	BHP	RPM	BHP	RPM	BHP	RPM	BHP
4000	<i>784</i>	<i>1.14</i>	<i>876</i>	<i>1.44</i>	959	1.76	1036	2.10	1108	2.47	1176	2.86	1239	3.26	1300	3.67
4200	<i>814</i>	<i>1.29</i>	<i>903</i>	<i>1.60</i>	983	1.93	1058	2.28	1129	2.66	1195	3.05	1258	3.46	1318	3.89
4400	<i>844</i>	<i>1.45</i>	930	1.78	1008	2.12	1081	2.48	1150	2.86	1215	3.26	1277	3.68	1337	4.12
4600	<i>874</i>	<i>1.63</i>	957	1.97	1034	2.32	1105	2.69	1172	3.08	1236	3.49	1297	3.92	1356	4.37
4800	<i>904</i>	<i>1.82</i>	986	2.17	1060	2.54	1129	2.92	1195	3.32	1258	3.74	1318	4.17	1375	4.63
5000	932	2.02	1014	2.39	1086	2.77	1159	3.16	1218	3.57	1280	4.00	1338	4.44	1395	4.91
5200	966	2.24	1043	2.62	1113	3.01	1179	3.42	1242	3.84	1302	4.27	1360	4.73	<i>1416</i>	<i>5.20</i>
5400	997	2.48	1071	2.87	1141	3.28	1205	3.70	1267	4.12	1326	4.57	1382	5.03	1437	5.51
5600	1029	2.74	1101	3.14	1168	3.56	1231	3.99	1291	4.43	1394	4.88	1405	5.36	1458	5.85

Notes:

- Selections in *ITALICS* require a field drive change. See following table below for drive ranges.
- Table includes all internal pressure drops including cabinet losses. See Pressure Drops table that must be considered as part of external static pressure drop.
- DO NOT SELECT IN SHADED AREAS (FOR INTERPOLATION ONLY).

SUPPLY FAN DRIVE DATA - PCB180

		Motor Sheave - Adjustable		Factory Setting			
		Fan Sheave - Fixed		2 Turns Opens			
Motor Sheave Turns Open		0	1	2	3	4	5
Fan RPM	5.0 HP Motor	1400	1446	1273	1209	1146	1082

Note: Allow ±5% variation in blower RPM due to pulley manufacturing tolerances.

Conversion Factor:

- 1 CFM = 0.472 L/S
- 1" W.C. = 2.5 M Bar
- 1 HP = 0.747 kW

PRODUCT SPECIFICATIONS

FAN PERFORMANCE DATA (CONT.)

COMPONENT PRESSURE DROPS

MODEL	CFM	WET COIL	ELEC. HEAT	MED. EFF. FILTERS	ECONO. RETURN AIR DAMPER
090	2600	0.06	0.03	0.03	0.14
	3000	0.06	0.04	0.04	0.14
	3400	0.07	0.05	0.05	0.18
120	3600	0.05	0.05	0.03	0.14
	4000	0.05	0.06	0.04	0.14
	4400	0.05	0.08	0.04	0.14
180	5000	0.13	0.10	0.06	0.18
	5400	0.13	0.12	0.06	0.21
	5600	0.16	0.13	0.08	0.23

COOLING CAPACITY DATA

PCB090-5 (SI UNITS)

INDOOR AIR		CONDENSER AIR TEMPERATURE														
L/S	WB	23.9°C			29.4°C			35.0°C			40.6°C			46.1°C		
		Total Cap.	Sens Cap.	Kw	Total Cap.	Sens Cap.	Kw	Total Cap.	Sens Cap.	Kw	Total Cap.	Sens Cap.	Kw	Total Cap.	Sens Cap.	Kw
1203	22.2	32.77	15.48	8.36	30.67	14.52	9.29	28.56	13.56	10.23	26.46	12.60	11.17	24.35	11.64	12.10
	19.4	30.23	18.70	7.82	28.17	17.90	8.73	26.11	17.10	9.64	24.05	16.31	10.55	21.99	15.51	11.46
	16.7	27.52	23.00	7.46	26.07	21.73	8.30	24.62	20.45	9.14	23.17	19.18	9.98	21.72	17.91	10.82
	13.9	26.59	24.96	7.18	24.98	23.20	8.06	23.38	21.43	8.94	21.77	19.67	9.83	20.17	17.91	10.71
1416	22.2	34.17	17.16	8.63	31.91	16.15	9.58	29.65	15.14	10.53	27.39	14.14	11.48	25.13	13.13	12.43
	19.4	31.36	21.95	8.08	29.28	20.81	9.01	27.20	19.66	9.93	25.12	18.52	10.86	23.03	17.38	11.78
	16.7	28.62	26.83	7.53	26.96	25.02	8.49	25.30	23.20	9.44	23.65	21.39	10.40	21.99	19.58	11.35
	13.9	28.62	26.83	7.53	26.96	25.02	8.49	25.30	23.20	9.44	23.65	21.39	10.40	21.99	19.58	11.35
1628	22.2	35.01	18.42	8.82	32.73	17.46	9.77	30.46	16.50	10.73	28.18	15.54	11.69	25.90	14.59	12.64
	19.4	32.19	24.67	8.28	30.10	23.35	9.21	28.00	22.04	10.14	25.91	20.72	11.07	23.81	19.40	11.99
	16.7	30.24	28.49	7.89	28.44	26.54	8.86	26.64	24.60	9.84	24.84	22.65	10.81	23.03	20.71	11.78
	13.9	30.24	28.49	7.89	28.44	26.54	8.86	26.64	24.60	9.84	24.84	22.65	10.81	23.03	20.71	11.78

Sensible heat capacities shown are based on 26.7°C DB entering air at the evaporator coil. For sensible heat capacities at other than 26.7°C DB, deduct 44.32 W per 47 L/S of evaporator coil air for each degree below 26.7°C, or add 44.32 W per 47 L/S of evaporator coil air per degree above 26.7°C.

PCB090-5 (ENGLISH UNITS)

INDOOR AIR		CONDENSER AIR TEMPERATURE														
SCFM	WB	75°F			85°F			95°F			105°F			115°F		
		Total Kbtuh	Sens Kbtuh	Kw	Total Kbtuh	Sens Kbtuh	Kw	Total Kbtuh	Sens Kbtuh	Kw	Total Kbtuh	Sens Kbtuh	Kw	Total Kbtuh	Sens Kbtuh	Kw
2550	72	111.8	52.8	8.36	104.6	49.6	9.29	97.5	46.3	10.23	90.3	43.0	11.17	83.1	39.7	12.10
	67	103.2	63.8	7.82	96.1	61.1	8.73	89.1	58.4	9.64	82.1	55.6	10.55	75.0	52.9	11.46
	62	93.9	78.5	7.46	89.0	74.1	8.30	84.0	69.8	9.14	79.1	65.5	9.98	74.1	61.1	10.82
	57	90.7	85.2	7.18	85.2	79.1	8.06	79.8	73.1	8.94	74.3	67.1	9.83	68.8	61.1	10.71
3000	72	116.6	58.5	8.63	108.9	55.1	9.58	101.2	51.7	10.53	93.5	48.2	11.48	85.7	44.8	12.43
	67	107.0	74.9	8.08	99.9	71.0	9.01	92.8	67.1	9.93	85.7	63.2	10.86	78.6	59.3	11.78
	62	97.6	91.6	7.53	92.0	85.4	8.49	86.3	79.2	9.44	80.7	73.0	10.40	75.0	66.8	11.35
	57	97.6	91.6	7.53	92.0	85.4	8.49	86.3	79.2	9.44	80.7	73.0	10.40	75.0	66.8	11.35
3450	72	119.5	62.9	8.82	111.7	59.6	9.77	103.9	56.3	10.73	96.2	53.0	11.69	88.4	49.8	12.64
	67	109.9	84.2	8.28	102.7	79.7	9.21	95.6	75.2	10.14	88.4	70.7	11.07	81.3	66.2	11.99
	62	103.2	97.2	7.89	97.0	90.6	8.86	90.9	83.9	9.84	84.7	77.3	10.81	78.6	70.7	11.78
	57	103.2	97.2	7.89	97.0	90.6	8.86	90.9	83.9	9.84	84.7	77.3	10.81	78.6	70.7	11.78

Sensible heat capacities shown are based on 80°F DB entering air at the evaporator coil. For sensible heat capacities at other than 80°F DB, deduct 84 BTU/h per 100 CFM of evaporator coil air for each degree below 80°F, or add 84 BTU/h per 100 CFM of evaporator coil air per degree above 80°F.

COOLING CAPACITY DATA (CONT.)

PCB120-5 (SI UNITS)

INDOOR AIR		CONDENSER AIR TEMPERATURE														
		23.9°C			29.4°C			35.0°C			40.6°C			46.1°C		
L/S	WB	Total Cap.	Sens Cap.	Kw	Total Cap.	Sens Cap.	Kw	Total Cap.	Sens Cap.	Kw	Total Cap.	Sens Cap.	Kw	Total Cap.	Sens Cap.	Kw
1605	22.2	43.67	21.02	9.95	41.04	19.52	11.27	38.41	18.03	12.59	35.78	16.54	13.91	33.15	15.04	15.23
	19.4	40.29	25.44	9.31	37.70	24.09	10.59	35.11	22.74	11.86	32.52	21.38	13.14	29.93	20.03	14.41
	16.7	36.65	31.24	8.89	34.88	29.22	10.07	33.11	27.19	11.25	31.34	25.17	12.43	29.57	23.14	13.61
	13.9	35.42	33.85	8.54	33.43	31.17	9.78	31.44	28.49	11.01	29.45	25.82	12.24	27.45	23.14	13.47
1888	22.2	45.54	23.30	10.28	42.71	21.72	11.62	39.87	20.13	12.96	37.04	18.55	14.30	34.20	16.96	15.64
	19.4	41.79	29.83	9.62	39.18	27.99	10.92	36.57	26.14	12.22	33.97	24.29	13.52	31.36	22.45	14.82
	16.7	38.12	36.41	8.95	36.07	33.63	10.29	34.03	30.85	11.62	31.98	28.07	12.95	29.93	25.29	14.29
	13.9	38.12	36.41	8.95	36.07	33.63	10.29	34.03	30.85	11.62	31.98	28.07	12.95	29.93	25.29	14.29
2170	22.2	46.65	25.03	10.50	43.81	23.49	11.85	40.96	21.94	13.20	38.11	20.39	14.55	35.26	18.84	15.90
	19.4	42.90	33.53	9.86	40.28	31.41	11.17	37.66	29.29	12.48	35.04	27.18	13.78	32.41	25.06	15.09
	16.7	40.29	38.65	9.39	38.05	35.67	10.75	35.82	32.70	12.11	33.59	29.72	13.46	31.36	26.75	14.82
	13.9	40.29	38.65	9.39	38.05	35.67	10.75	35.82	32.70	12.11	33.59	29.72	13.46	31.36	26.75	14.82

Sensible heat capacities shown are based on 26.7°C DB entering air at the evaporator coil. For sensible heat capacities at other than 26.7°C DB, deduct 44.32 W per 47 L/S of evaporator coil air for each degree below 26.7°C, or add 44.32 W per 47 L/S of evaporator coil air per degree above 26.7°C.

PCB120-5 (ENGLISH UNITS)

INDOOR AIR		CONDENSER AIR TEMPERATURE														
		75°F			85°F			95°F			105°F			115°F		
SCFM	WB	Total Kbtuh	Sens Kbtuh	Kw	Total Kbtuh	Sens Kbtuh	Kw	Total Kbtuh	Sens Kbtuh	Kw	Total Kbtuh	Sens Kbtuh	Kw	Total Kbtuh	Sens Kbtuh	Kw
3400	72	149.0	71.7	9.95	140.0	66.6	11.27	131.1	61.5	12.59	122.1	56.4	13.91	113.1	51.3	15.23
	67	137.5	86.8	9.31	128.6	82.2	10.59	119.8	77.6	11.86	111.0	73.0	13.14	102.1	68.4	14.41
	62	125.1	106.6	8.89	119.0	99.7	10.07	113.0	92.8	11.25	106.9	85.9	12.43	100.9	79.0	13.61
	57	120.9	115.5	8.54	114.1	106.4	9.78	107.3	97.2	11.01	100.5	88.1	12.24	93.7	79.0	13.47
4000	72	155.4	79.5	10.28	145.7	74.1	11.62	136.1	68.7	12.96	126.4	63.3	14.30	116.7	57.9	15.64
	67	142.6	101.8	9.62	133.7	95.5	10.92	124.8	89.2	12.22	115.9	82.9	13.52	107.0	76.6	14.82
	62	130.1	124.2	8.95	123.1	114.7	10.29	116.1	105.3	11.62	109.1	95.8	12.95	102.1	86.3	14.29
	57	130.1	124.2	8.95	123.1	114.7	10.29	116.1	105.3	11.62	109.1	95.8	12.95	102.1	86.3	14.29
4600	72	159.2	85.4	10.50	149.5	80.1	11.85	139.8	74.9	13.20	130.0	69.6	14.55	120.3	64.3	15.90
	67	146.4	114.4	9.86	137.5	107.2	11.17	128.5	100.0	12.48	119.6	92.7	13.78	110.6	85.5	15.09
	62	137.5	131.9	9.39	129.9	121.7	10.75	122.2	111.6	12.11	114.6	101.4	13.46	107.0	91.3	14.82
	57	137.5	131.9	9.39	129.9	121.7	10.75	122.2	111.6	12.11	114.6	101.4	13.46	107.0	91.3	14.82

Sensible heat capacities shown are based on 80°F DB entering air at the evaporator coil. For sensible heat capacities at other than 80°F DB, deduct 84 BTU/h per 100 CFM of evaporator coil air for each degree below 80°F, or add 84 BTU/h per 100 CFM of evaporator coil air per degree above 80°F.

PCB180-5 (SI UNITS)

INDOOR AIR		CONDENSER AIR TEMPERATURE														
		23.9°C			29.4°C			35.0°C			40.6°C			46.1°C		
L/S	WB	Total Cap.	Sens Cap.	Kw	Total Cap.	Sens Cap.	Kw	Total Cap.	Sens Cap.	Kw	Total Cap.	Sens Cap.	Kw	Total Cap.	Sens Cap.	Kw
2246	22.2	64.17	29.53	16.42	60.17	28.00	18.63	56.17	26.48	20.83	52.17	24.95	23.04	48.17	23.43	25.25
	19.4	59.19	35.59	15.36	55.27	34.49	17.50	51.35	33.39	19.63	47.42	32.29	21.76	43.50	31.20	23.89
	16.7	53.86	43.83	14.67	51.14	41.88	16.64	48.42	39.93	18.61	45.69	37.99	20.59	42.97	36.04	22.56
	13.9	52.05	47.66	14.10	49.01	44.75	16.15	45.97	41.85	18.21	42.93	38.94	20.27	39.90	36.04	22.33
2643	22.2	66.90	32.71	16.97	62.61	31.14	19.21	58.31	29.56	21.45	54.01	27.99	23.68	49.71	26.42	25.92
	19.4	61.40	41.82	15.87	57.44	40.10	18.05	53.48	38.39	20.22	49.53	36.68	22.40	45.57	34.96	24.57
	16.7	56.02	51.22	14.77	52.89	48.26	17.00	49.76	45.30	19.23	46.63	42.34	21.46	43.50	39.38	23.68
	13.9	56.02	51.22	14.77	52.89	48.26	17.00	49.76	45.30	19.23	46.63	42.34	21.46	43.50	39.38	23.68
3039	22.2	68.54	35.09	17.33	64.22	33.66	19.59	59.89	32.22	21.85	55.57	30.78	24.11	51.24	29.34	26.37
	19.4	63.03	47.01	16.27	59.05	45.02	18.46	55.07	43.02	20.64	51.09	41.02	22.83	47.11	39.03	25.01
	16.7	59.20	54.38	15.49	55.79	51.20	17.76	52.38	48.02	20.03	48.98	44.84	22.30	45.57	41.66	24.57
	13.9	59.20	54.38	15.49	55.79	51.20	17.76	52.38	48.02	20.03	48.98	44.84	22.30	45.57	41.66	24.57

Sensible heat capacities shown are based on 26.7°C DB entering air at the evaporator coil. For sensible heat capacities at other than 26.7°C DB, deduct 44.32 W per 47 L/S of evaporator coil air for each degree below 26.7°C, or add 44.32 W per 47 L/S of evaporator coil air per degree above 26.7°C.

PRODUCT SPECIFICATIONS

COOLING CAPACITY DATA (CONT.)

PCB180-5 (ENGLISH UNITS)

INDOOR AIR		CONDENSER AIR TEMPERATURE														
		75 °F			85 °F			95 °F			105 °F			115 °F		
SCFM	WB	Total Kbtuh	Sens Kbtuh	Kw	Total Kbtuh	Sens Kbtuh	Kw	Total Kbtuh	Sens Kbtuh	Kw	Total Kbtuh	Sens Kbtuh	Kw	Total Kbtuh	Sens Kbtuh	Kw
4760	72	219.0	100.8	16.42	205.3	95.6	18.63	191.7	90.4	20.83	178.0	85.1	23.04	164.4	79.9	25.25
	67	202.0	121.4	15.36	188.6	117.7	17.50	175.2	113.9	19.63	161.8	110.2	21.76	148.4	106.5	23.89
	62	183.8	149.6	14.67	174.5	142.9	16.64	165.2	136.3	18.61	155.9	129.6	20.59	146.6	123.0	22.56
	57	177.6	162.6	14.10	167.2	152.7	16.15	156.9	142.8	18.21	146.5	132.9	20.27	136.1	123.0	22.33
5600	72	228.3	111.6	16.97	213.6	106.3	19.21	199.0	100.9	21.45	184.3	95.5	23.68	169.6	90.1	25.92
	67	209.5	142.7	15.87	196.0	136.9	18.05	182.5	131.0	20.22	169.0	125.2	22.40	155.5	119.3	24.46
	62	191.1	174.8	14.77	180.5	164.7	17.00	169.8	154.6	19.23	159.1	144.5	21.46	148.4	134.4	23.68
	57	191.1	174.8	14.77	180.5	164.7	17.00	169.8	154.6	19.23	159.1	144.5	21.46	148.4	134.4	23.68
6440	72	233.9	119.7	17.33	219.1	114.8	19.59	204.4	109.9	21.85	189.6	105.0	24.11	174.9	100.1	26.37
	67	215.1	160.4	16.27	201.5	153.6	18.46	187.9	146.8	20.64	174.3	140.0	22.83	160.7	133.2	25.01
	62	202.0	185.6	15.49	190.4	174.7	17.76	178.8	163.9	20.03	167.1	153.0	22.30	155.5	142.1	24.57
	57	202.0	185.6	15.49	190.4	174.7	17.76	178.8	163.9	20.03	167.1	153.0	22.30	155.5	142.1	24.57

Sensible heat capacities shown are based on 80 °F DB entering air at the evaporator coil. For sensible heat capacities at other than 80 °F DB, deduct 84 BTU/h per 100 CFM of evaporator coil air for each degree below 80 °F, or add 84 BTU/h per 100 CFM of evaporator coil air per degree above 80 °F.

EVAPORATOR MOTOR HEAT

Horsepower/(kW)	BTU/h (KW)
2 (1.49)	4400 (1.29)
3 (2.24)	6200 (1.82)
5 (3.73)	10,500 (3.08)

APPLICATION DETAILS AND ACCESSORIES

FACTORY SUPPLIED ACCESSORIES THERMOSTAT (CHT90-120)

Two-stage cool and two-stage heat thermostat with subbase, Manual changeover, Fan ON or AUTO. Note: A variety of thermostat configurations can be used on this equipment based on the application needs. For example our CHTS36-60 can be used if two-stage cooling and single-stage heat is desired. Our CHT18-60 can be used if single-stage cooling and heating is desired. A single-stage cooling and two-stage heating thermostat can be used.

ROOFTOP LIFT KIT (RLK90-120)

Kit consists of four ½" (12.7mm) shackles that are used to lift the equipment into position on a roof, etc. The shackles are to be attached to the mounting holes in the base rails. Wire or strap material along with field supplied spreader bars are employed to complete the lifting assembly (See Rigging detail).

LOW AMBIENT CONTROL (LA-01)

Liquid temperature (or pressure) operated solid state control, which varies the speed of one of the condenser fans. Low ambient control reduces fan motor RPM as liquid temperature (or pressure) decreases. Caution: If control is used below 50 °F (10 °C) accumulators should be added to the equipment to avoid slugging of the compressors.

ROOF CURB (PGC-5)

Full perimeter curb for equipment in the down discharge application. Curb includes provisions for duct attachment prior to setting unit. Curb is shipped knocked down with all necessary hardware and gasket material.

MANUAL AND MOTORIZED FRESH AIR DAMPERS (PGMD-5 & PGMDM-5)

Manual damper is fixed position type for 0 to 25% fresh air. Motorized damper is a field adjustable mechanical damper for 0 to 25% fresh air, damper automatically closes when blower stops.

ECONOMIZERS (PGED 090/102-5 & PGED 120/180-5)

Fully modulating, enthalpy controlled economizers shipped with major components pre-assembled. Plug assembly on equipment and economizer provides easy wiring.

HORIZONTAL DUCT KIT (PGHDK 090/102-5 & PGHDK 120/180-5)

The unit is shipped in the down flow (vertical) duct configuration. The horizontal duct kit must be installed in the field for horizontal duct configuration.

PANEL LOUVER KIT (PLK090/102-5 & PLK120/180-5)

Louvered panels for condenser coil protection.

HEAT KIT ACCESSORY

Slide in heat kit from 15 to 30 kW @ 415V, 3Ph, 50 Hz are available. For 380/415V operation the -4 electrical designation on HKCB heat kits must be used. The heating output is derated as shown by example on page 11 at both 380V & 415V.

Bulletin illustrations cover the general appearance of Goodman Manufacturing Company, L.P., products at the time of publication, and we reserve the right to make changes in design and construction at any time without notice.

QUALITY MAKES THE DIFFERENCE!

All of our systems are designed and manufactured with the same high-quality standards, regardless of size or efficiency. We have designed these units to significantly reduce the most frequent causes of product failure. They are simple to service and forgiving to operate. We use quality materials and components. Finally, every unit is run-tested before it leaves the factory. That's why we know...there's no better quality.

Visit our website at
www.goodmanmfg.com for information on:
Goodman Products • Customer Services • Parts

Goodman Manufacturing Company, L.P.
2550 North Loop West, Suite 400
Houston, Texas 77092 USA

Goodman Manufacturing Company, L.P., reserves the right to discontinue, or change at any time, specifications or designs without notice or without incurring obligations.
Copyright © 2003 Goodman Manufacturing Company, L.P. • Houston, Texas • Printed in the USA. • Goodman products are made proudly in the USA.